

BOTTOM VIEW

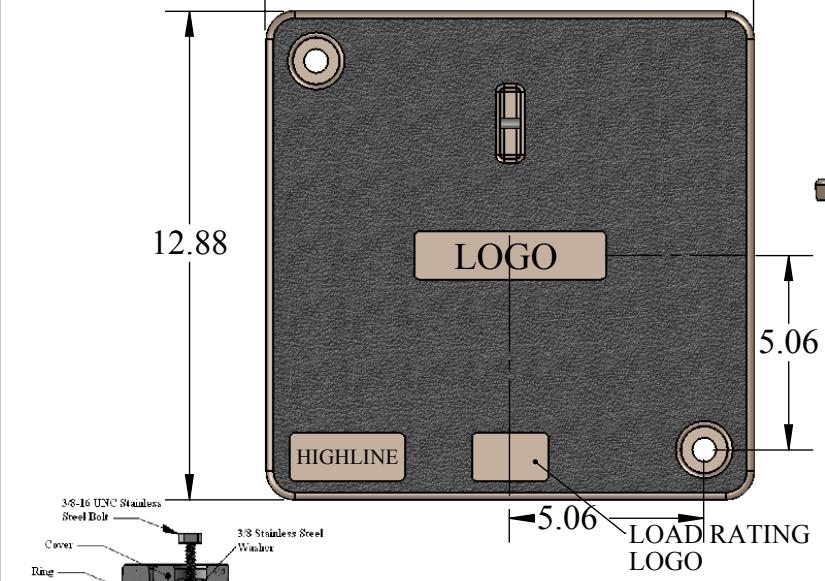

Box Only: CHB121218

Cover Only: CHC1212XXX

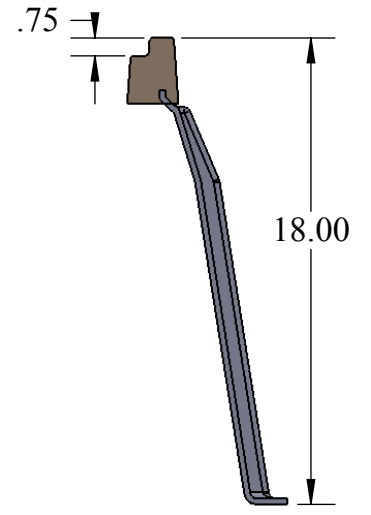
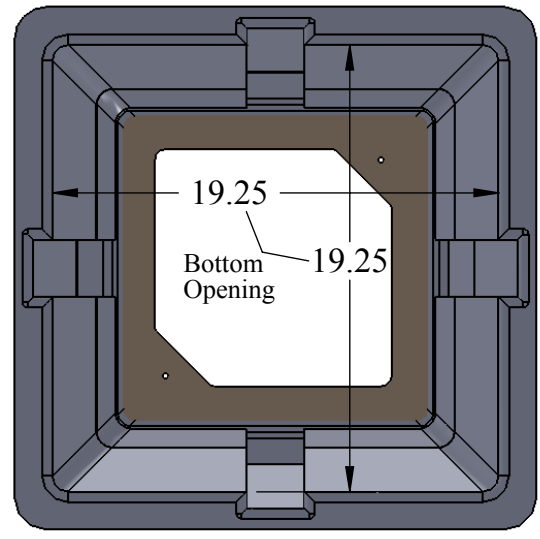
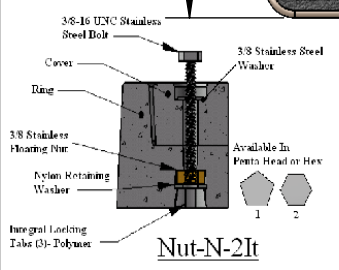
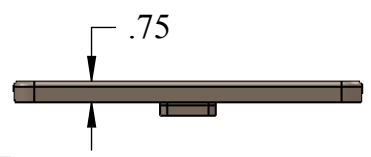
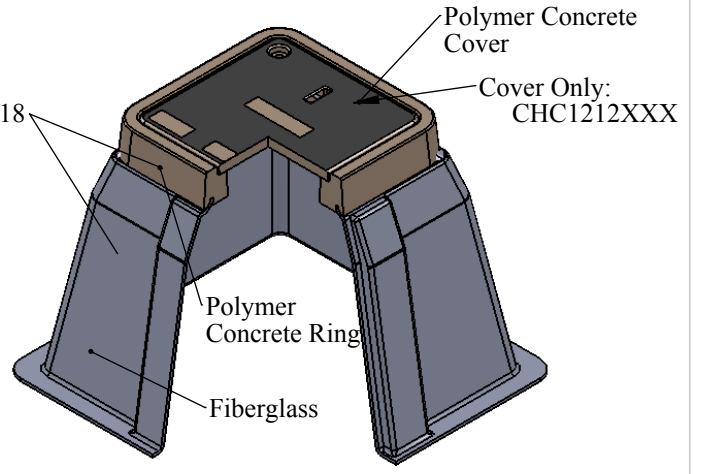

Rev. B was for Cover Dimension Change

PROPRIETARY AND CONFIDENTIAL
 THE INFORMATION CONTAINED IN THIS DRAWING IS THE SOLE PROPERTY OF HIGHLINE PRODUCTS. ANY REPRODUCTION IN PART OR AS A WHOLE WITHOUT THE WRITTEN PERMISSION OF HIGHLINE PRODUCTS IS PROHIBITED.

UNLESS OTHERWISE SPECIFIED:	NAME	DATE
DIMENSIONS ARE IN INCHES TOLERANCES: +/- 1/8"	DRAWN/ ENG. SK	05.24.11
FRACTIONAL ±	CHECKED	
ANGULAR: MACH ± BEND ±	HIGHLINE APPR.	
TWO PLACE DECIMAL ±	MFG APPR.	
THREE PLACE DECIMAL ±	Q.A.	
INTERPRET GEOMETRIC TOLERANCING PER:	BOX WEIGHT = 44 lbs.	
MATERIAL: Polymer Concrete/ Fiberglass	COVER WEIGHT= 10 lbs.	
FINISH	UNITS PER PALLET= # 24	
DO NOT SCALE DRAWING		



Composite Handhole Assembly
 Model CHA121218
 Tier8 (S) 12,000lbs., Tier15 (H) 22,500 lbs.

SIZE	DWG. NO.	REV
A	CHA121218	B
SCALE: NTS		SHEET 1 OF 1