

# HL-PED 1812 Stakeless Pedestal

## PRODUCT FEATURES

- All the advantages of fiberglass construction.
  - The precision and strength of match metal molding.
  - Pigment and UV protection throughout.
  - Impervious to environmental conditions.
- Easy to install.
- Easy lift off lid — NEW DESIGN.
- Safety engineered.
  - No internal exposed metal surfaces.
  - Double safe locking arrangement.
  - Tamperproof lock mechanism. (\*Patent Pending)
- Dimensions:
  - Top: 18"x12"x24"
  - Base: 21"x15"x30"
  - Overall Height: 52"
- Patent pending.

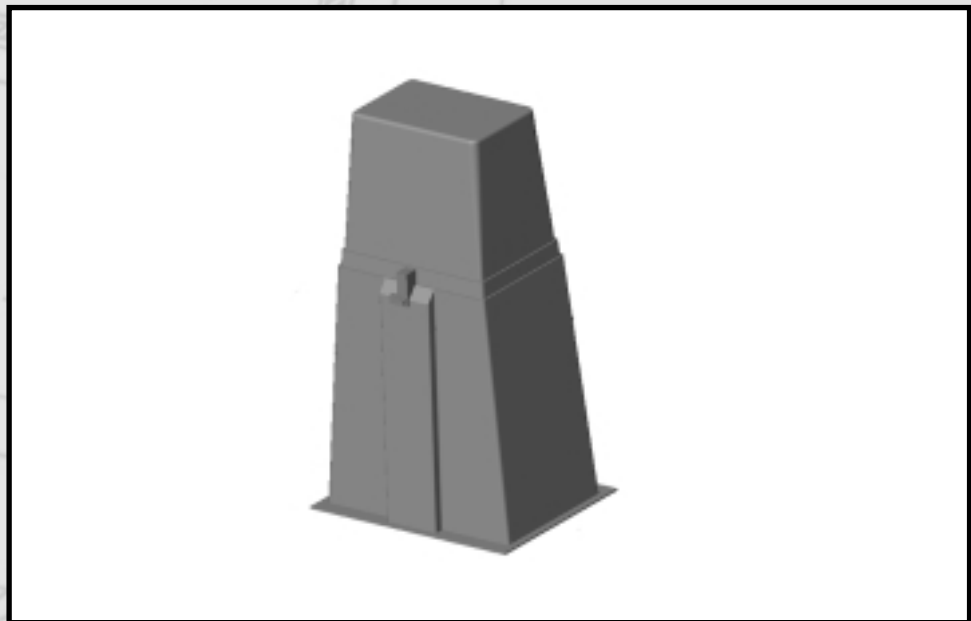

# Stakeless Pedestal

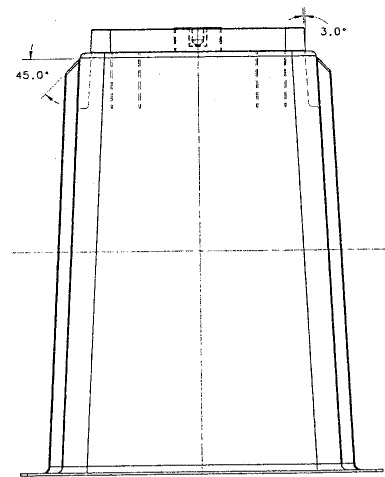
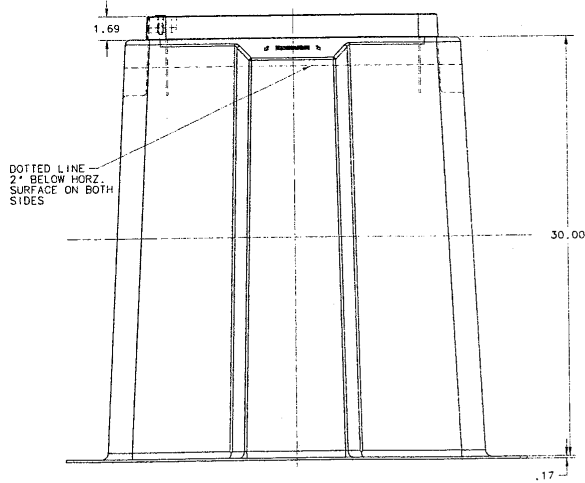
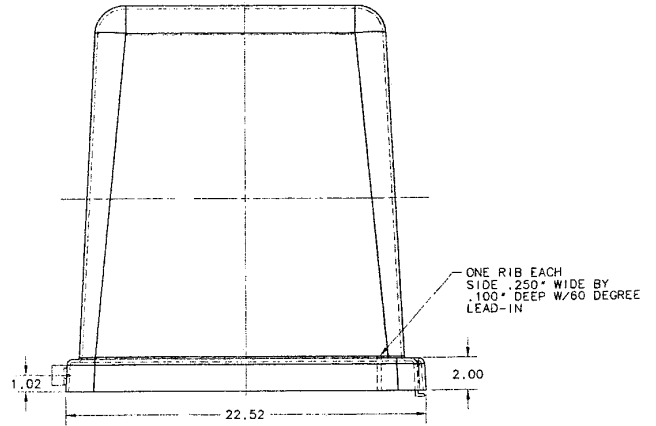
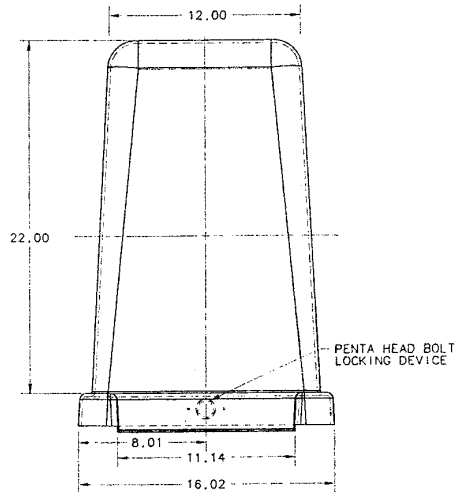

Additional sizes available  
See pages 36-37.