

## PRODUCT FEATURES

- Stainless steel hardware hex head or penta head bolt.
- High top-load strength; lightweight.
- Reduced side angle for easier readjust to grade.
- Single or double pipe ports available.
- U.V. stable for longer field life.
- Nestable for storage or shipping.
- Available in four standard colors: green, gray, black, or lavender.
- Box and lid ship fully assembled.

## STOCK COVER IDENTIFICATIONS

- Irrigation control valve (ICV)
- Water (solid or meter door)
- Electric (green or gray)
- Reclaimed water (green or lavender)
- Blank (no cover marking)
- Sewer
- RCV
- CATV
- Telephone
- Street lighting

When ordering, please specify color, cover identification, and bolt down type. For use in non-vehicle traffic areas. Not recommended for installation in concrete or asphalt without felt expansion joint.

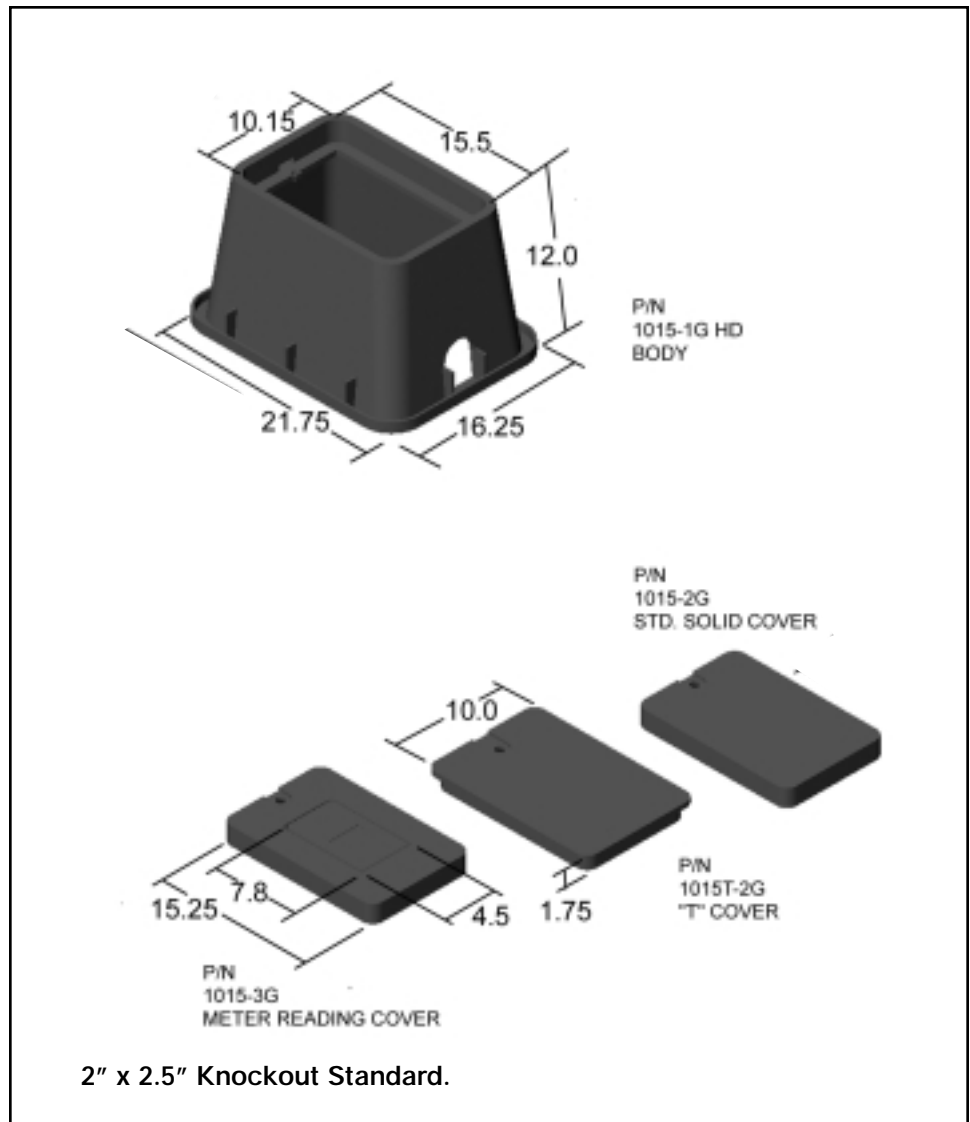

12" RECTANGULAR • 72 per pallet

Catalog Number	Description	Weight
1015-1G2G	12" Body & Solid Cover	9.5 Lbs.
1015T-1G2G	12" Body 2 "T" Cover	9.6 Lbs.
1015-1G3G	12" Body & Meter Reading Cover	9.5 Lbs.
1015-1G	12" Body Only	7.3 Lbs.
1015-2G	Cover Solid	2.0 Lbs.
1015T-2G	Cover "T" Cover	2.5 Lbs.
1015-3G	Cover Meter Reading	2.25 Lbs.
1015-4G	Captive Hinged Cover	3.0 Lbs.