

Series 1015 - 6" Extension Body

PRODUCT FEATURES

- For 6" extension of standard 12" rectangular box.
- High top-load strength.
- U.V. stable for longer field life.
- Available in four standard colors: green, gray, black, or lavender.
- Stainless steel hardware hex head or penta head bolt.

STOCK COVER IDENTIFICATIONS

- Irrigation control valve (ICV)
- Water (solid or meter door)
- Electric (green or gray)
- Reclaimed water (green or lavender)
- Blank (no cover marking)
- Sewer
- RCV
- CATV
- Telephone
- Street lighting

When ordering, please specify color, cover identification, and bolt down type. For use in non-vehicle traffic areas. Not recommended for installation in concrete or asphalt without felt expansion joint.

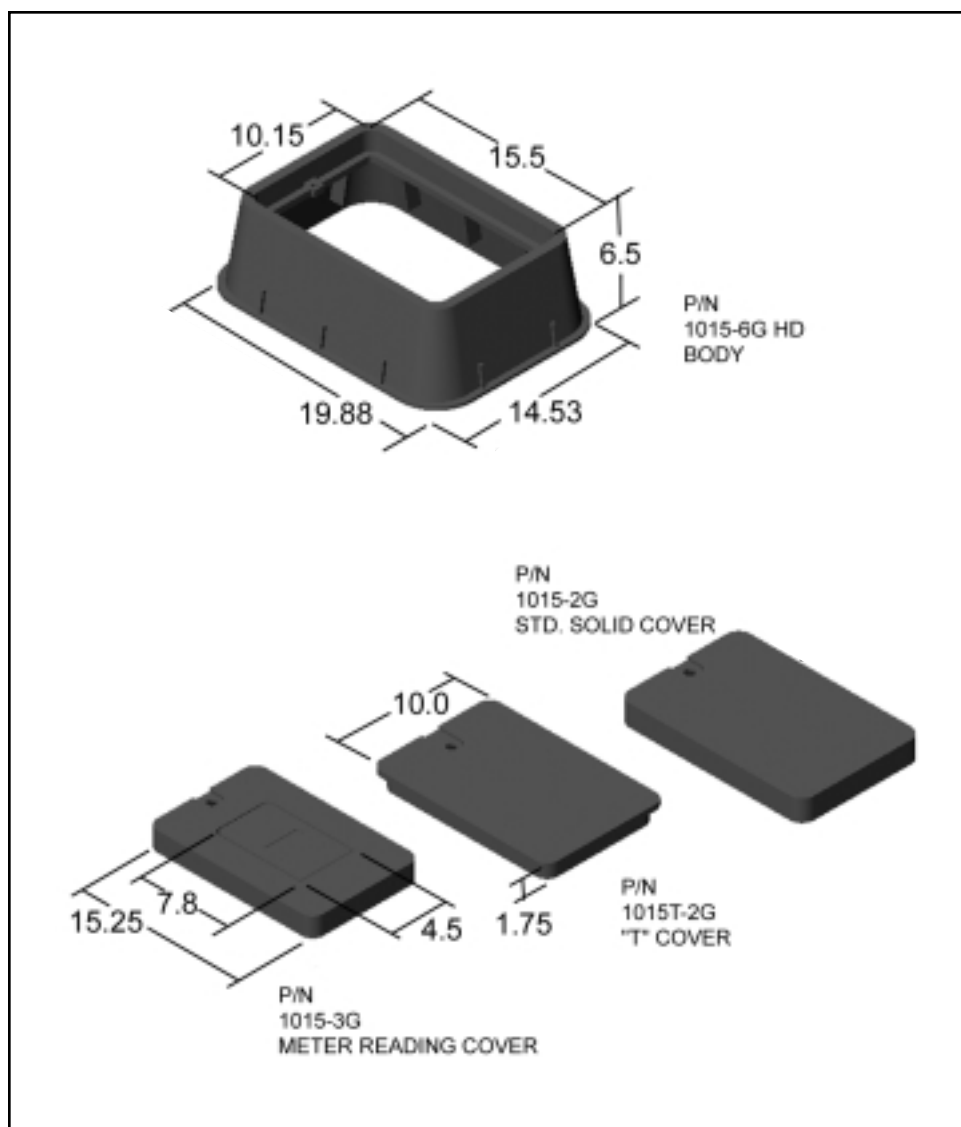

12" RECTANGULAR • 72 per pallet

Catalog Number	Description	Weight
1015-XG2G	6" Body & Solid Cover	6.0 Lbs.
1015-XG	6" Body Only	4.0 Lbs.
1015-2G	Cover Solid	2.0 Lbs.
1015-2G	Cover T Cover	2.25 Lbs.